

Digital ATS Controller

**ACD-III-D****User Manual**

REV : 0.0

**O-Sung Electric Machinery CO.,LTD.**

136, Hantaemal-gil, Wollong-myeon, Paju-si, Gyeonggi-do, 10945, Rep. of KOREA

Tel.: (031) 944-3521 / Fax: (031) 944-3525

Web site: /http://www.osemco.com / E-mail: ousung@chol.com

- Table of Contents -

<b>1. Safety Instruction</b> -----	<b>(3~4p)</b>
1.1 Precaution for Transportation	
1.2 Precaution for Installation	
1.3 Precaution for Operation	
1.4 Precaution for Repairing, Inspecting, and Exchanging	
1.5 Precaution before Operating	
<b>2. Composition of Product</b> -----	<b>(5~9p)</b>
2.1 Standard Specification	
2.2 Certified Standard	
2.3 Appearance	
<b>3. Set-up</b> -----	<b>(10~14p)</b>
3.1. Language Set-up	
3.2. System Set-up	
3.3. Power Set-up	
3.4. ATS Timer	
3.5. Generator Timer	
3.6. Generator Test	
3.7. Remote Communication Set-up	
3.8. Checking Equipment	
3.9 Event Records	
<b>4. ATS Control</b> -----	<b>(15~16p)</b>
4.1 Automatic Operation	
4.2 Manual Operation	
<b>5. Communication</b> -----	<b>(17p)</b>
5.1 MODBUS Protocol	
5.2 REQUEST(04h)	
5.3 COMMAND(05h)	
<b>6. Product Dimension</b> -----	<b>(18p)</b>
6.1 Product Dimension	
6.2 Panel Cutting	
<b>7. Connection Diagram</b> -----	<b>(19~20p)</b>
7.1 T3,TB3 Connection Diagram	
7.2 PC, PSO Connection Diagram	
7.3 TN,TBN Connection Diagram	
7.4 PCN Connection Diagram	

## 1. Safety Instruction

This instruction contains important safety contents.

Before operating the machine, please read all the instructions carefully related to the machine, and operate right.

Operate after learning all machine information, precautions and safety information.

This instruction classifies degree of risk by indicating [Danger] and [Caution]



Danger

Urgent situation when death or serious disaster occur



Caution

Potential situation when little defect or slight damage occur

### 1.1 Precaution for transportation



Caution

- Do not throw or put weighted material on the machine.
- Do not open enclosure with knife or sharp materials.

### 1.2 Precaution for installation



Caution

- .
- Only certified technician should install machine. **Electric shock may occur.**
- Before installation, open the switchgear and relative products to block all power. **Conflagration may occur**
- Use standard torque to tight bolts on terminal.
- Place machine on flat and horizontal ground.
- Do not install machine where there are high temperature, humidity, dust, corrosive gas, vibration, and impact.
- **Conflagration and malfunction may occur.**
- Any debris or liquid should not be applied to install machine.
- **Conflagration and malfunction may occur.**

### 1.3 Precaution for operation

- Do not contact main circuit or control terminal when the current is applying.



Danger

**Electric shock may occur.**

- Do not place machine at the outside.

**Conflagration may occur**

### 1.4 Precaution for repairing, inspecting and exchanging.



Caution

- Only expert should be allowed to repair and inspect.
- It is necessary to OFF the switch on manual operation condition and check the main circuit or control circuit being charged. **Electric shock may occur.**
- Main circuit terminal or connector should be checked periodically.  
**Conflagration and malfunction may occur due to faulty disconnect.**

### 1.5 Precaution before operating

After installation and before operation, please check the A power and phase direction of B power.

Also check the voltage and frequency stay normal status.

## 2. Composition of Product

### 2.1 Standard Specification

#### 2.1.1 Data

- 1) Model : ACD-III-D
- 2) Control Power : DC 12 ~ 24[V] / 0.5A
- 3) Size : (W)169.3mm x (H)88.7mm x (D)57mm
- 4) Product weight : 1.2Kg (including packing box)
- 5) Usage temperature : -25 ~ 70[°C]
- 6) Voltage input : A-POWER(prevaling voltage) 3P4W 380/220V / L-N 110[V] ~ 270[V] / 50[Hz] ~ 60[Hz].  
B-POWER(generating voltage) 2P / L-N 110[V] ~ 270[V] / 50[Hz] ~ 60[Hz].

#### 2.1.2 Hardware Specification

- 1) MICOM : RENESAS 16-BIT
- 2) Display : 128 x 64 Graphic LCD, High intensity LED
- 3) Contact input : ATS condition contact 2 Contacts, Function contact 5 Contacts
- 5) Relay Output : ATS A Input/Open 2 contacts, ATS B Input/Open 2 Contacts, Generator Operating 1 contact, Elevator Signal 1 Contact (Max AC250[V] 5[A])
- 6) Communication Function : RS485 1 Contact

#### 2.1.3 Main Function

- 1) ATS Automatic Operation : Priority or operation time can be set-up
- 2) ATS Manual Operation
- 3) Surveillance of Normal Power :
- 4) Surveillance of Generating Power :
- 5) Generator Maneuver Output:
- 6) Reserve Operation
- 7) Interlock Elevator
- 8) Provide Korean menu and English menu

## 2.2 Certified Standard

**KC Certified Registration Number : MSIP-REM-OS0-ACD-III-D (National Radio Research Agency)**

#### EMC TEST :

- 1) KN 61000-6-4 Conductivity Block Test
- 2) KN 61000-6-4 Radioactivity Block Test
- 2) KN 61000-4-2 Electrostatic Discharge Tolerance Test
- 2) KN 61000-4-3 Radioactivity RF Electromagnetic field Tolerance Test
- 2) KN 61000-4-4 Bust Tolerance Test
- 2) KN 61000-4-5 Surge Tolerance Test
- 2) KN 61000-4-6 Conductivity RF Electromagnetic field Tolerance Test
- 2) KN 61000-4-11 Voltage dip and Moment Blackout Tolerance Test

## 2.3 Appearance

### 2.3.1. The front







### 2.3.2 LED Display

① Normal Power (Green) :	ON - Power ON	OFF - Power OFF	BLINK - Malfunction
② Generator Power (Green) :	ON - Power ON	OFF - Power OFF	BLINK - Malfunction
③ Normal On (Red) :	ON - ATS input	OFF - ATS Open	BLINK - Input or Open stand by
④ Generator On (Red) :	ON - ATS input	OFF - ATS Open	BLINK - Input or Open stand by
⑤ Test (White) :	ON - Test Condition		

### 2.3.3 Control Button

Butto Shape	Button Name	Function of Button
	ATS "A"(Normal) Manual Control Button	Manual input or manual open ATS to "A"(Normal) on manual condition ( Operate after pressing about 0.5 seconds ) <i>* ON(input) function can be used according to ATS model or Operation set-up.</i>
	ATS "B"(Generating) Manual Control Button	Manual input or manual open ATS to "B"(Generating) on manual condition ( Operate after pressing about 0.5 seconds ) <i>* ON(input) function can be used according to ATS model or Operation set-up.</i>
	Operating Test Test	Use or cancel the automatic test to "B"(Generating) on automatic mode ( Operate after pressing about 0.5 seconds )
	Immediate implement Override	Use it when you ignore the set-up time to operate immediately on automatic mode.

### 2.3.4 Set-up Button

Button Shape	Button Name	Function of Button
	Setup / Enter	Change main screen to set-up screen (Press about 1 seconds) Change set-up screen to main screen or enter changed value <i>*Automatic operation and ATS control function can be stopped when you set up.</i>
	UP	Change the screen from main screen Shift or increase the set-up value from the set-up screen
	DOWN	Change the screen from main screen Shift or decrease the set-up value from the set-up screen
	MOVE	Move to detailed set-up from the set-up screen Move to set-up value from set-up screen

### 2.3.5 LCD Display

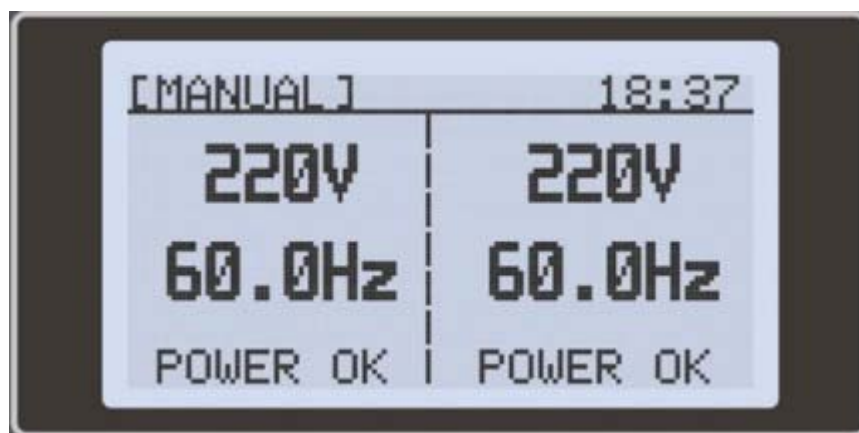

#### LCD Indicating Condition

- 1) Operating mode, Current time, Timer condition
- 2) "A"(Normal) voltage, frequency. "B"(Generating) voltage, frequency.
- 3) Both power's voltage condition, malfunction condition

2.3.6 The Back

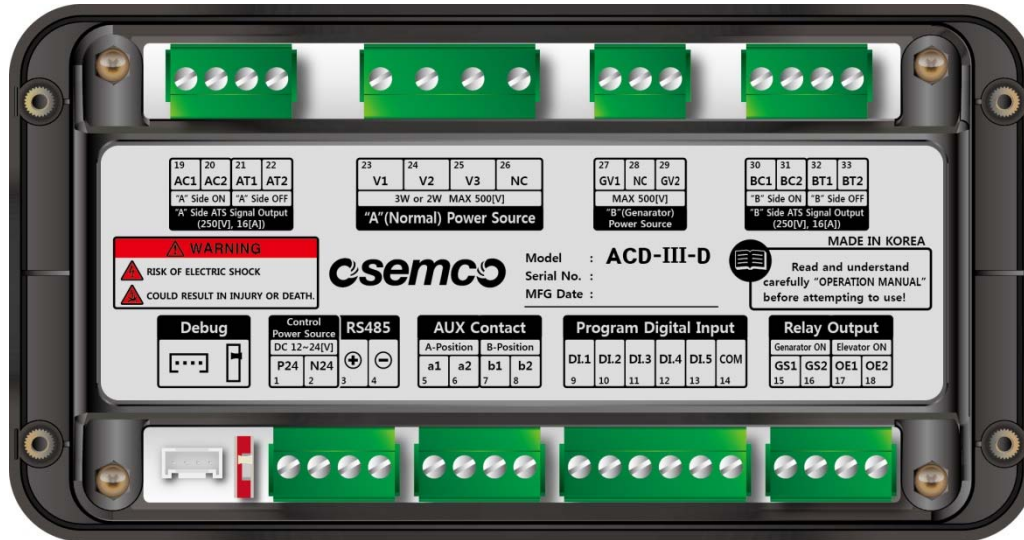

2.3.7 Composition of Terminal

Control Power Source			<Control power of Controller>
Number	Terminal	Signal	Function of Terminal
1	P24	Power	Controller power input Input range : DC 12~24[V], 0.5A
2	N24		

\* It can be damaged if you input reversed direction or overvoltage.

RS485			<RS485 Communication Terminal>
Number	Terminal	Signal	Function of Terminal
3	RS485 +	Communication	RS485 Communication Port, MODBUS / RTU
4	RS485 -		

AUX Contact			<ATS auxiliary switch terminal>
Number	Terminal	Signal	Function of Terminal
5	a1	Contact input	Condition Contact input port of ATS "A"(Normal)
6	a2		
7	b1		Condition Contact input port of ATS "B"(Generating)
8	b2		

\* It can be damaged if you apply external voltage. (Read the connection diagram)

Program Digital Input			
Number	Terminal	Signal	Function of Terminal
9	DI.1	Contact input	ATS "A"(Normal) external open(trip) signal or no switchover signal input port
10	DI.2		ATS "B"(Generating) external open(trip) signal or no switchover signal input port
11	DI.3		Maintain current condition signal input port on operating elevator
12	DI.4		External Test signal input port
13	DI.5		External Override signal input port
14	COM		DI.1 ~ DI.5 contact input common signal

\* It can be damaged if you apply external voltage.

## Relay Output

Number	Terminal	Signal	Function of Terminal
15	GS1	Relay output	Generator operating signal (N/O, 250[V] 5[A])
16	GS2		
17	OE1		No operating elavator signal (N/O, 250[V] 5[A])
18	OE2		

## "A" Side ATS Signal Output

Number	Terminal	Signal	Function of Terminal
19	AC1	Relay output	ATS A input signal output (250[V] 16[A])
20	AC2		
21	AT1		ATS A Open(Trip) signal output (250[V] 16[A])
22	AT2		

## "A"(Normal) Power Source

Number	Terminal	Signal	Function of Terminal
23	V1	Voltage input	A voltage output (MAX 500[V]) Three poles : V1, V2, V3 input Single pole : V1, V3 input
24	V2		
25	V3		
26	N.C		

\* N.C terminal is no usage auxiliary terminal.

## "B"(Generator) Power Source

Number	Terminal	Signal	Function of Terminal
27	GV1	Voltage input	B voltage input (MAX 500[V])
28	N.C		
29	GV2		

\* N.C terminal is no usage auxiliary terminal.

## "B" Side ATS Signal Output

Number	Terminal	Signal	Function of Terminal
30	BC1	Relay output	ATS B input signal output (250[V] 16[A])
31	BC2		
32	BT1		ATS B Open(Trip) signal output (250[V] 16[A])
33	BT2		

### 3. Set-up

#### 3.1. Language Set-up

>Language Set-up	Option : KOREAN, ENGLISH	Standard : KOREAN
Set-up the language		

#### 3.2. System Set-up

>Operating Mode	Option : Manual, Automatic	Standard : Auto
Set-up the operating mode		

>ATS type	Option : A-B, A-N-B	Standard : A-B
Set-up ATS type		

\* Do not use (3 positions) A-N-B mode if you use Trip possible ATS model ( ex : PCN, TN, TBN, ATCB )

\* Use (2 positions) A-B mode if you use ATS model which has no Trip capacity. ( ex : PC, PSO, T3 )

\* A-B mode can be selected even for Trip possible ATS model without changing the wire..

>Date Set-up	Option : 20XX-XX-XX-X	Standard : Current
Set-up the year, month, and date.		

\* Use for reservation of operation and event recording.

>Time Set-up	Option : XX:XX	Standard : Current
Set-up time		

\* Use for reservation of operation and event recording.

>Display OFF	Option:No use,10min,30min,1 hour	Standard : No use
Set up the automatic off of LCD back light		
Back light would automatically off without pressing button for set-up time and without any change on power condition.		
The back light would automatically light on when you press button and there is any change on power condition.		

>Confidential Terminal Set-up	Option : 0001 ~ 9999	Standard : 0000
Set-up the password		
Initial password is 0000, in this case, there is no password check.		
You can not set-up 0000 after you have changed the password.		

\* Once setting-up the password, you can check the set-up value, but you cannot make any set-up alterations without checking the password

## 3.3. Power Set-up

>A Power input	Option : 1P-2W, 3P-3W	Standard : 3P-3W
Set-up the A power input condition - 1P-2W(Single pole) case : Use V1, V3 - 3P-3W(Three poles) case : Use V1, V2, V3 If you set up 1P-2W, [Open Phase Use] would change to [No Use] automatically.		

>Voltage Set-up	Range : 100 ~ 500[V]	Standard : 220[V]
Set-up the both(A and B) rated voltage.		

>Frequency Set-up	Option : 50, 60[Hz]	Standard : 60[Hz]
Set-up the both(A and B) rated frequency.		

>PT ratio	Range : (001.0 ~ 100.0)/(0.1 ~ 1.0)	Standard : 001.0/1.0
Set-up PT ratio, when PT being used		

>Over voltage Set	Range : 105 ~ 130[%]	Standard : 110[%]
Set-up the level of over voltage. ([%] for rated voltage) When the level of over voltage set lower than the level of over voltage rst, - The level of over voltage rst sets 101[%] automatically, when the level of over voltage set 105[%]. - The level of over voltage rst sets (Over Volt Set - 5)[%], when the level of over volt sets higher than 106[%].		

>Over voltage RST	Range :(level of set-5)~(level of set-1)[%]	Standard:105[%]
Set-up the level of over voltage rst. ([%] for rated voltage)		

>Under Voltage Set	Range : 85 ~ 95[%]	Standard : 90[%]
Set-up the level of Under Voltage Set. ([%] for rated voltage) When the level of set sets higher than the level of RST, - The level of RST sets 99[%] automatically, when the level of set sets 95[%]. - The level of RST sets (The level of Set+5)[%], when the level of set sets lower than 94[%].		

>Under Voltage RST	Range :( level of set+1)~(level of set+5)[%]	Standard : 95[%]
Set-up the Under Voltage RST. ([%] for rated voltage)		

>Over Freq SET	Range : (rated+1) ~ (rated+6) [Hz]	Standard : 66[Hz]
----------------	------------------------------------	-------------------

Setup the level of Over Freq SET.

When the level of Over Freq SET has lower value than the level of Over Freq RST,

- The level of RST setup (rated+1)[Hz] automatically when the level of SET has lower value than (rated+4)[Hz].
- The level of RST setup (SET-4)[Hz] automatically when the level of SET has higher value than (rated+5)[Hz]

>Over Freq RST	Range : (rated+1) ~ (level of SET-1)[Hz]	Standard : 62[Hz]
----------------	--	-------------------

Setup the level of Over Freq RST.

>Under Freq SET	Range : (rated-6) ~ (rated-1) [Hz]	Standard : 54[Hz]
-----------------	------------------------------------	-------------------

Setup the level of Under Freq SET

When the level of Under Freq SET is higher than the level of Under Freq RST,

- The level of RST setup (rated-1)[Hz] automatically when the level of SET is higher than (rated-4)[Hz].
- The level of RST setup (SET+4)[Hz] automatically when the level of SET is lower than (rated-5)[Hz]

>Under Freq RST	Range : (level of SET+1) ~ (rated-1)[Hz]	Standard : 58[Hz]
-----------------	--	-------------------

Setup the level of Under Freq RST

>Open Phase Protection	Option : Not use, Use	Standard : Use
------------------------	-----------------------	----------------

Setup the Open Phase Protection function on 3P-3W

You cannot setup on 1P-2W

### 3.4. ATS Timer

>A▶B XFER DELAY (ATS A-B type)	Range : 00sec ~ 90min 59sec	Standard : 05sec
--------------------------------	-----------------------------	------------------

On ATS A-B type, setup delay time from B to A.

\* Prevent unnecessary operations from momentary shutdown on Normal Power.

>B▶A XFER DELAY (ATS A-B type)	Range : 00sec ~ 90min 59sec	Standard : 05sec
--------------------------------	-----------------------------	------------------

On ATS A-B type, setup delay time from A to B.

\* Recover without unnecessary time take.

>N▶A XFER DELAY (ATS A-N-B type)	Range : 00sec ~ 90min 59sec	Standard : 05sec
----------------------------------	-----------------------------	------------------

On ATS A-N-B type, setup delay time from Neutral to A.

>N▶B XFER DELAY (ATS A-N-B type)	Range : 00sec ~ 90min 59sec	Standard : 05sec
----------------------------------	-----------------------------	------------------

On ATS A-N-B type, setup delay time from Neutral to B.

>A▶N XFER DELAY (ATS A-N-B type)	Range : 00sec ~ 90min 59sec	Standard : 05sec
----------------------------------	-----------------------------	------------------

On ATS A-N-B type, setup delay time from A to Neutral.

>B▶N XFER DELAY (ATS A-N-B type)	Range : 00sec ~ 90min 59sec	Standard : 05sec
----------------------------------	-----------------------------	------------------

On ATS A-N-B type, setup delay time from B to Neutral

### 3.5. Generator Timer

>GEN START DELAY	Range : 00sec ~ 90min 59sec	Standard : 05sec
Setup the START DELAY time.		

>GEN STOP DELAY	Range : 00sec ~ 90min 59sec	Standard : 05sec
Setup the STOP DELAY time		

### 3.6. Generator Test

>Gen Test n	Option : No use, Unload operation, Load operation	Standard : No use
Setup the use of Generator Test		
- Unload : Start/Stop the generator for setup test time.		
- Load : After starting the generator, it transfers to ATS generating for setup test time.		

>Test n Period	Range : (1~5)week (SUN~SAT)	Standard : 1week
Setup the Test Period		

>Test n Time	Range : (00:00 ~ 23:59)~(00:00 ~ 23:59)	Standard: 00:00~00:00
Setup the Test Time		
Do not test if starting and finishing time are identical or starting time be set after finishing time.		

### 3.7. Remote Communication Setup

>MODBUS ID	Range : 01 ~ 64	Standard : 01
Setup MODBUS ID of RS485 communication port.		

>MODBUS BAUD	Option : 9600, 19200, 38400[bps]	Standard : 9600[bps]
Setup the communication speed of RS485 communication port.		

### 3.8. Checking Equipment

>A-TRANSFERS	Not Optional	Inquiry Possible
Check the number of transfer to "A"		

>B-TRANSFERS	Not Optional	Inquiry Possible
Check the number of transfer to "B".		

>A-USAGE TIME	Not Optional	Inquiry Possible
Check the usage time on "A"		

>B-USAGE TIME	Not Optional	Inquiry Possible
Check the usage time on "B".		

>OPEN TIME	Not Optional	Inquiry Possible
Check usage time on Open status.		

### 3.9. Event Records

>Event Records 0001~1024	Not Optional	Inquiry Possible
<p>Check chronologically about transfer, malfunction, and maneuver events.</p> <ul style="list-style-type: none"><li>- Power ON, Manual Mode, Auto Mode, Test Start, Test Finished, Starting Generator, Stopping Generator</li><li>- AP Transfer Disable ON, AP Transfer Disable OFF, BP Transfer Disable ON, BP Transfer Disable OFF</li><li>- ELEV. Input ON, ELEV. Input OFF, ELEV. Output ON, ELEV. Output OFF</li><li>- AP Manual Input, AP Manual Open, AP Auto Input, AP Auto Open, AP Power OFF, AP Power ON</li><li>- AP Open Phase, AP Over voltage, AP Under voltage, AP Over frequency, AP Under frequency, AP Input Fail, AP Open Fail</li><li>- BP Manual Input, BP Manual Open, BP Auto Input, BP Auto Open, BP Power OFF, BP Power ON</li><li>- BP Open Phase, BP Over voltage, BP Under voltage, BP Over frequency, BP Under frequency, BP Input Fail, BP Open Fail</li></ul>		

## 4. ATS Control

### Auto / Manual Set-up

- 1) Operation Condition Indication : [AUTO] or [MANUAL] is displayed on LCD screen.
- 2) Changing Operation Condition : Pressing SETUP button 2sec > System Setup > Option setup changes on operation mode.

Ex) Auto setup method :

Pressing setup button for 2sec > System setup > Operation mode > Auto > Pressing setup button twice

Ex) Manual setup method :

Pressing setup button for 2sec > System setup > Operation mode > Manual > Pressing setup button twice

### 4.1. Automatic Operation

- 1) Monitor the abnormal voltage of "A"(Normal) power
  - > Identify as normal power when over voltage, under voltage, over frequency, and under frequency stay in normal range.
- 2) Monitor the abnormal voltage of "B"(Generating) power.
  - > Identify as normal power when over voltage, under voltage, over frequency, and under frequency stay in normal range..
- 3) Automatically operate ATS after time delay whichever power is normal
- 4) "A"(Normal) power has priority when the both power is normal. (A(Normal) power priority)
- 5) When the both power in abnormal status, it stands by whenever the both power turn normal.
- 6) Output signal bees for third time in 3sec periodically when there is failure to control due to malfunction or miswiring. After repeating beeps for third times, and staying fail to supply, it is considered as ATS malfunction(Indicating status with warning and on the LCD screen)
- 7) The relay output maintain time is 0.5 sec for inputting and tripping.
- 8) Entering setup mode, all automatic facility pause except for generating output facility.

#### 4.1.1 ATS "A"(Normal) external trip signal and no switchover input (DI.1 , COM)

- 1) On automatic operation, it forces to Open(Trip) of ATS A(Normal) and limits automatic input with interlocking external relay contact of "A"(Normal)

#### 4.1.2 ATS "B"(Generating) external trip signal and no switchover input (DI.2 , COM)

- 1) On automatic operation, it forces to Open(Trip) of ATS B(Generating) and limits automatic input with interlocking external relay contact of "B"(Generating)

#### 4.1.3 Operation input of Elevator (DI.3 , COM)

- 1) On automatic operation, whichever power being normally used, it maintains current using power switchover status after inputting operation signal of elevator.
- 2) Elevator being activated by using Normal or Generating power postpones switchover followed by priority or Test condition and stands by complete the operation.

#### 4.1.4 External Test signal input (DI.4 , COM)

- 1) It activates after forming frontal Test button to external control with contact input.
- 2) Activate Test operation after inputting. (Frontal Test lamp ON)
  - > Outputting generating contact (GS1, GS2)
  - > Checking voltage of generator (GV1, GV2)
  - > After delay time, it trips and switchover to "B"(Generating) power
  - > Maintain current status of ATS "B"(Generating) if there is any problems to operating power
- 3) Activating automatic operation after releasing input. (Frontal Test lamp OFF)

#### 4.1.5 External Override Signal Input (DI.5 , COM)

- 1) It activates after forming frontal Override button to external control with contact input.
- 2) On automatic operation, it activates all setup delay operations immediately. (Cancel delay operations)

#### 4.1.6 Generating operation output on automatic mode (GS1, GS2)

- 1) It outputs generating contact after setup generating delay time when there are any problems such as frost, under voltage, over voltage, under frequency, and over frequency at "A"(Normal) power
- 2) OFF the generating contact output after recovering ATS completely with delay time.
- 3) To setup the generating delay time or pause the generating delay time, Press SETUP button for 2 sec > Generator Timer

#### 4.1.7 Elevator output on automatic mode (OE1, OE2)

- 1) Output contacts when there are any problems on operating power..
- 2) It can be used for limiting elevator use. (No temporary use)

### 4.2. Manual Operation

- 1) All ATS operation can be controlled by manual button or communication.
- 2) Input and Open(Trip) can be controlled by manual button or communication control when "A"(Normal) power stays normal. (Only input is accessible for A-B control setup)
- 3) Input and Open(Trip) can be controlled by manual button or communication control when "B"(Generating) power stays normal. (Only input is accessible for A-B control setup)
- 4) Press button about 0.5sec for operating. ( Prevent malfunction )
- 5) Indicate error on power or switchover status during manual operation.
- 6) The relay output maintain time is 0.5 sec for inputting and tripping.
- 7) No generating output on manual mode.

## 5. Communication Protocol

### 5.1 MODBUS Protocol

- 1) METHOD : 2-Wire RS485
- 2) PROTOCOL : MODBUS / TRU
- 3) FUNCTION : REQUEST(04h), COMMAND(05h)
- 4) Number : 1~64
- 5) BAUDRATE : 9600[bps], 19200[bps], 38400[bps]
- 6) PARITY : (None)
- 7) DATA BIT : 8[Bit]
- 8) STOP BIT : 1[Bit]
- 9) MINIMAL INTERVAL : 250[ms]
- 10) PACKET ENDING TIME : 5[ms]

### 5.2 REQUEST(04h)

TX EXAMPLE : 01 04 00 00 00 14 CRC16 → Request 20 data from 30001.

Address	Clause	Data Type	Data Indicate	
30001	Device Model	UNSIGNED 16BIT	-	
30002	A-Power V1-V2 Voltage	UNSIGNED 16BIT	XXX [V]	
30003	A-Power V2-V3 Voltage	UNSIGNED 16BIT	XXX [V]	
30004	A-Power V3-V1Voltage	UNSIGNED 16BIT	XXX [V]	
30005	B-Power V1-V2 Voltage	UNSIGNED 16BIT	XXX [V]	
30006	A-Power Frequency	UNSIGNED 16BIT	XX.X [Hz]	
30007	B-Power Frequency	UNSIGNED 16BIT	XX.X [Hz]	
30008	Malfunction Status		UNSIGNED 16BIT	-
	Bit 0 : A-Power Open Phase	Bit 8 : Reserved		
	Bit 1 : A-Power Under Voltage	Bit 9 : B-Power Under Voltage		
	Bit 2 : A-Power Over Voltage	Bit 10 : B-Power Over Voltage		
	Bit 3 : A-Power Under Frequency	Bit 11 : B-Power Under Frequency		
	Bit 4 : A-Power Over Voltage	Bit 12 : B-Power Over Frequency		
	Bit 5 : A Input Fail	Bit 13 : B Input Fail		
	Bit 6 : A Open Fail	Bit 14 : B Open Fail		
Bit 7 : Reserved	Bit 15 : Reserved			
30009	FAN Operation Output Status		UNSIGNED 16BIT	-
	Bit 0 : Auto Mode	Bit 8 : Reserved		
	Bit 1 : Test Mode	Bit 9 : Reserved		
	Bit 2 : A-Power Status	Bit 10 : Reserved		
	Bit 3 : B-Power Status	Bit 11 : Reserved		
	Bit 4 : A Input Status	Bit 12 : Reserved		
	Bit 5 : B Input Status	Bit 13 : Reserved		
	Bit 6 : A Malfunction Status	Bit 14 : Reserved		
Bit 7 : B Malfunction Status	Bit 15 : Reserved			

### 5.3 COMMAND(05h)

TX EXAMPLE : 01 05 00 02 FF 00 CRC16 → ATS A manual input signal for 0003

Address	Clauses	Data
0001	Manual Mode	0xFF00 Auto Clear
0002	Automatic Mode	
0003	A Manual Input	
0004	B Manual Input	
0005	A Manual Open	
0006	B Manual Open	

6. Product Dimension

6.1 Product Dimension

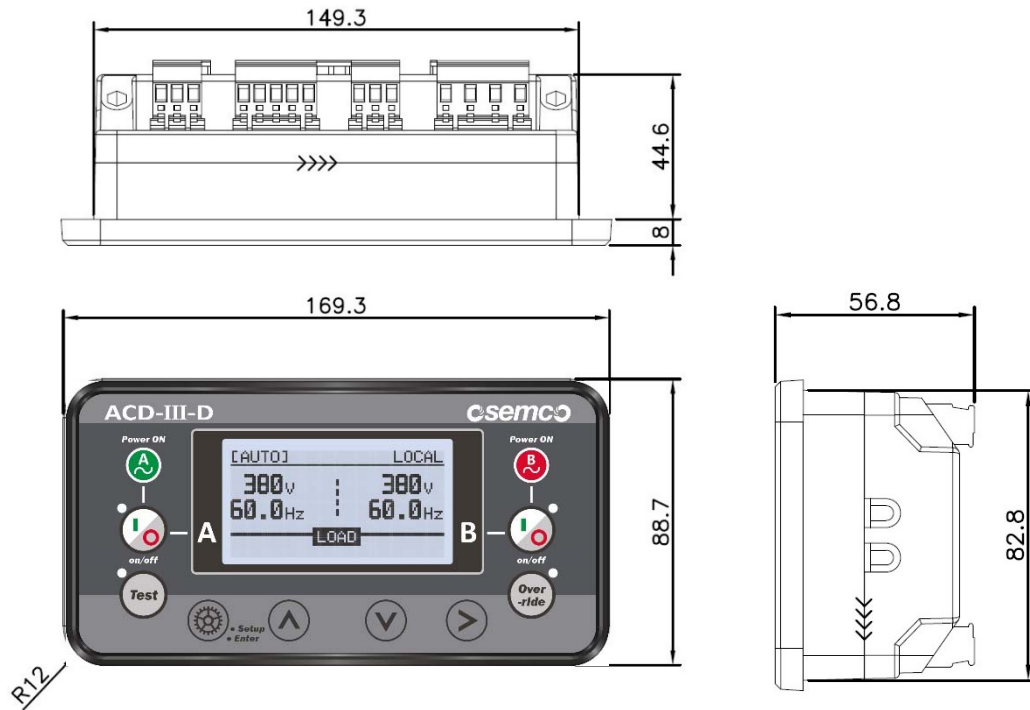

6.2 Panel Cutting

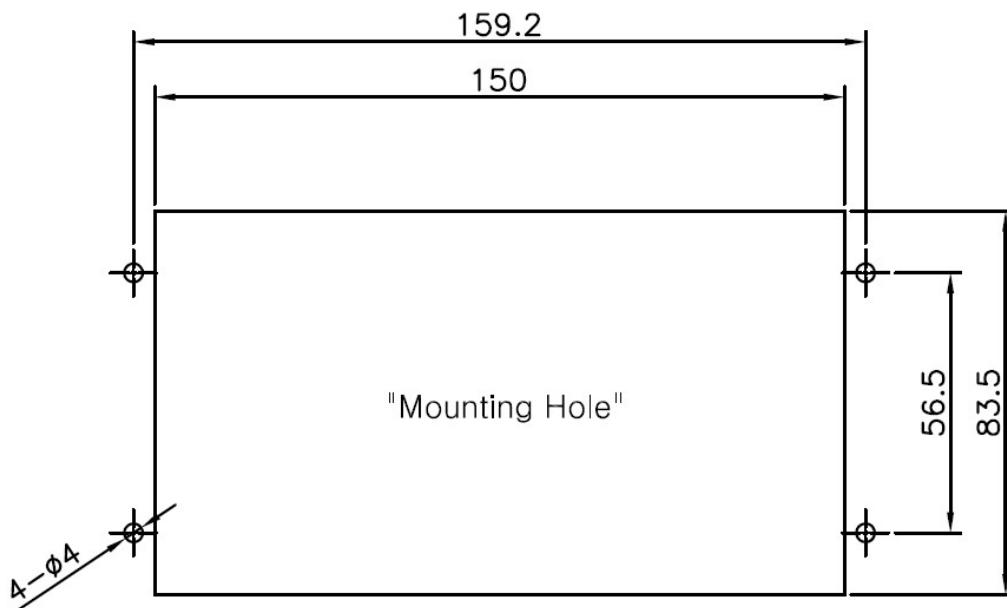

7. Connection Diagram

7.1 T3, TB3, TO, TBO Connection Diagram

ACD-III-D 3φ4W 380/220V

OSS-T3, TB3, TO, TBO (AC220V)

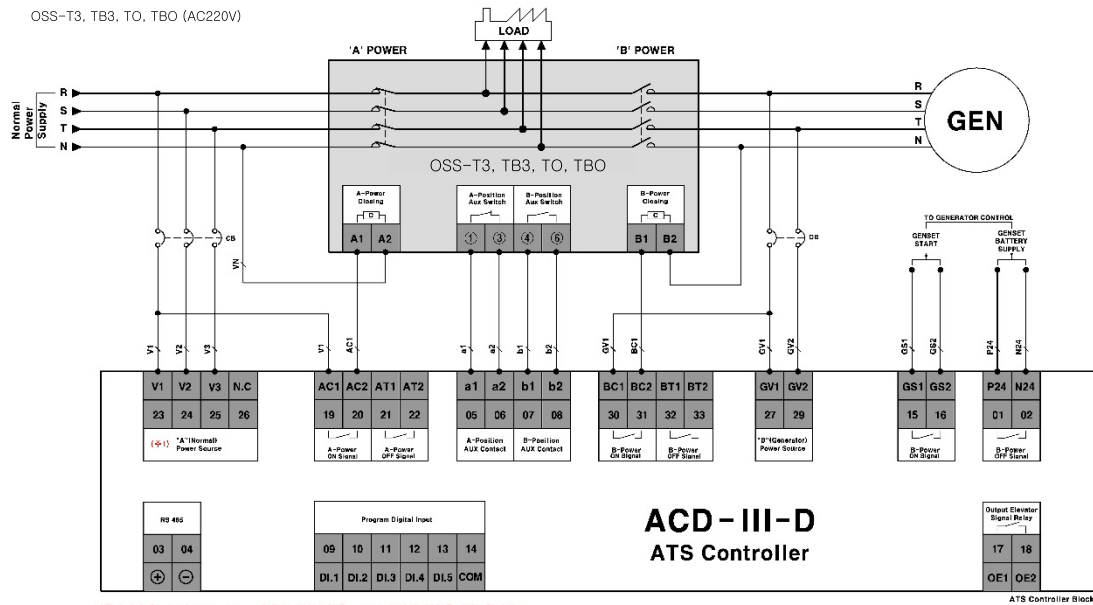

(주1) 'A' (Normal) POWER Source 입력이 단상인 경우 V1, V3 단자에 전원을 입력 합니다.

7.2 PC, PSO Connection Diagram

ACD-III-D 3φ4W 380/220V

OSS-PC, PSO Type (AC220V)

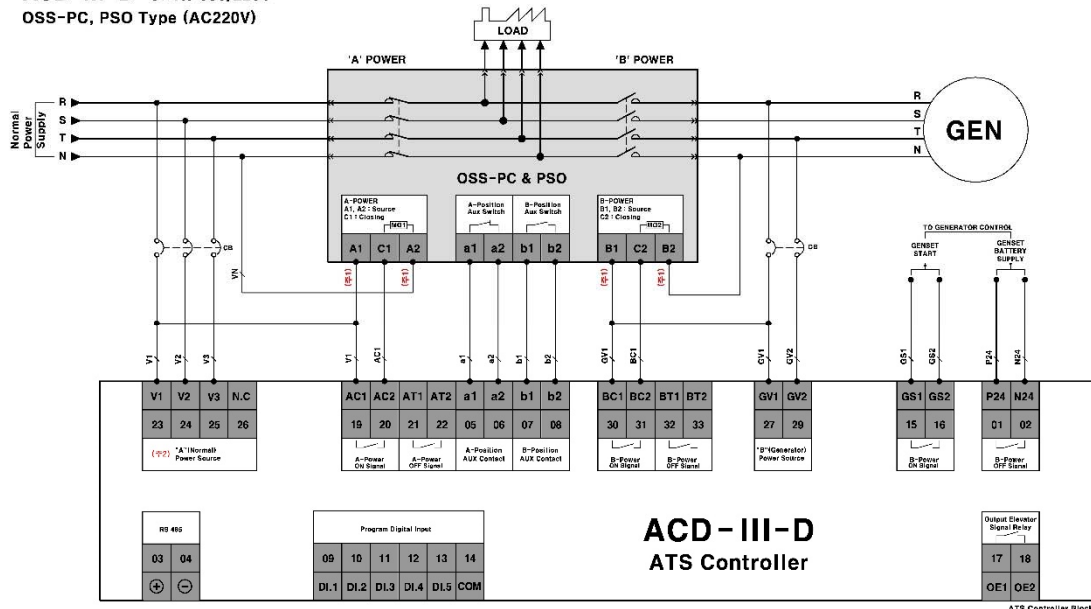

(주1) ATS 1,000A 이하 사용자 권선의 규격은 2.0mm<sup>2</sup> 이상 사용합니다.  
ATS 2,000A 이상 사용자 권선의 규격은 4.0mm<sup>2</sup> 이상 사용합니다.  
ATS 4,000A 이상 사용자 권선의 규격은 6.0mm<sup>2</sup> 이상 사용합니다.

(주2) 'A' (Normal) POWER Source 입력이 단상인 경우 V1, V3 단자에 전원을 입력 합니다.

7.3 TN,TBN Connection Diagram

ACD-III-D 3φ4W 380/220V  
OSS-TN, TBN Type (AC220V)

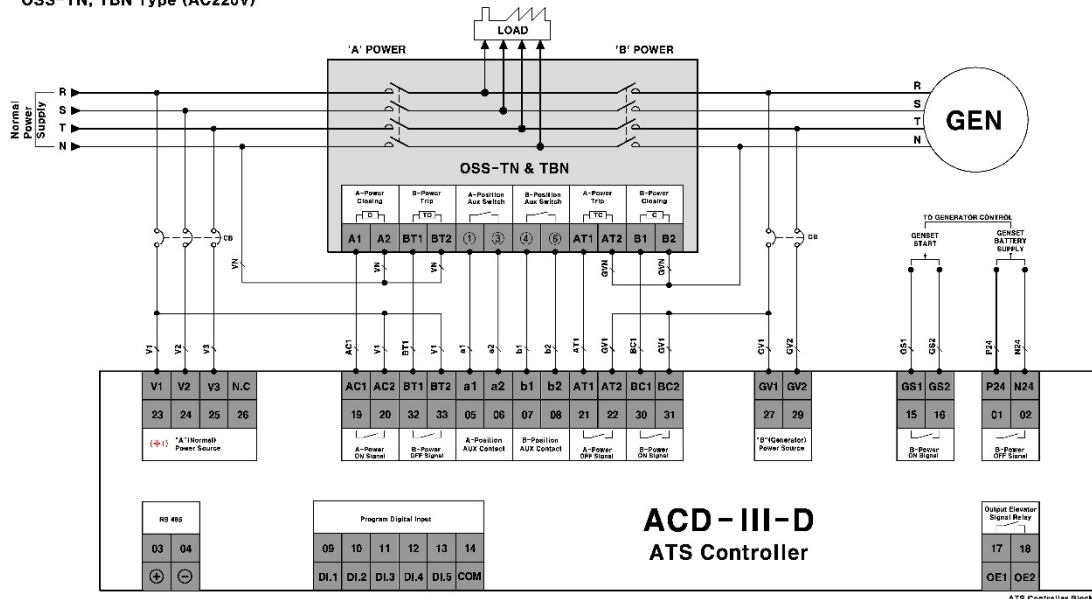

(주1) "A" (Normal) POWER Source 입력이 단상인경우 V1, V3 단자에 선원을 입력 합니다.

7.4 PCN Connection Diagram

ACD-III-D 3φ4W 380/220V  
OSS-PCN ( 800A ~ 1,600A) Type (AC220V)

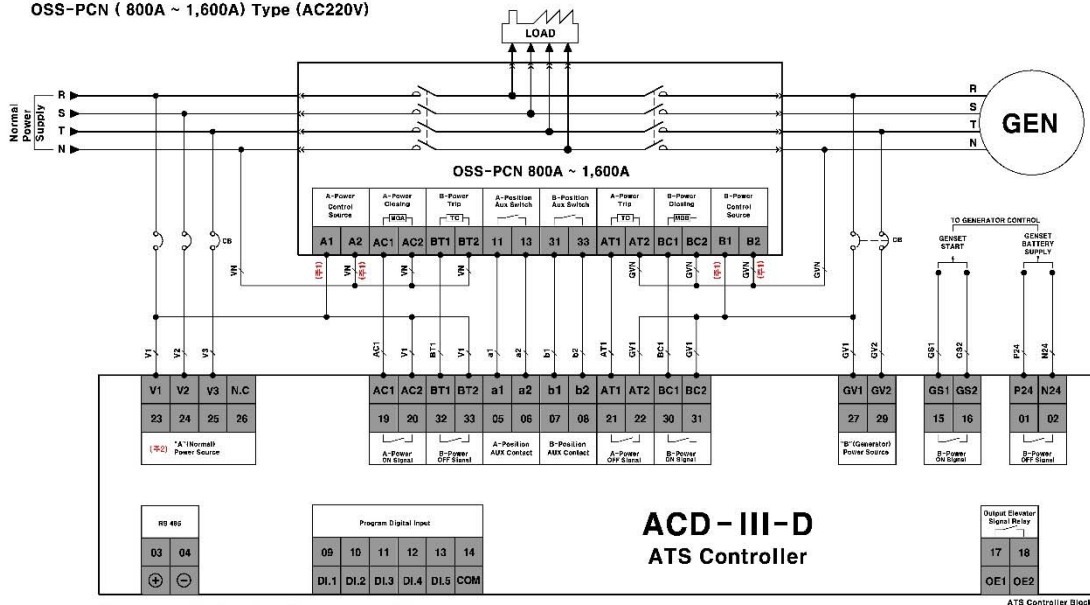

(주1) ATS 1,600A 이하 사용자 권선의 굵기는 2.5mm<sup>2</sup> 이상 사용합니다.

(주2) "A" (Normal) POWER Source 입력이 단상인경우 V1, V3 단자에 중점을 입력 합니다.